

CATANA

CATAMARANS



carboninfusion



INDEX

INDEX..... 2

SPECIFICATIONS 3

DESIGN 4

CONSTRUCTION..... 5

EXTERIORS 6

INTERIOR LAYOUTS 9

TECHNICAL EQUIPMENTS 13

COMMISSIONING..... 13



SPECIFICATIONS

Model: OCEAN CLASS

Naval Architect: CATANA Design Team

Structural warranty: 5 years

Hull length: 14.99 M / 49'1"

Length overall: 15.75 M / 51'7" (with fixed bowsprit)

Maximum beam: 7.98M (26'2")

Draft, daggerboards raised: 1.39 M / 4'6"

Draft, daggerboards down: 2.52 M / 8'3"

Unladen weight: 13.5 T

Engines: 2 x 45 hp saildrive

Diesel: 2 x 400 L (2 x 105 US gal)

Fresh water: 2 x 400 L (2 x 105 US gal)

CE Certification:

- Cat. A : 8 pax (One liferaft of 8 pax)
- Cat. B : 12 pax (One liferaft of 12 pax)
- Cat. C : 20 pax (Two liferaft of 10 pax)
- Cat. D : 30 pax (no liferaft needed)



DESIGN

- Inclined hulls and fine entry bows to benefit heading and speed
- Mast set farther aft with large foretriangle for balance under sail and ease of handling
- Good bridgedeck clearance for optimal comfort at sea
- Fine daggerboards to reduce drag with electric raising and lowering
- Expanded loft-style living space that includes a large living room, spacious L-shaped kitchen, dedicated office and lounge area with a large sleeping berth



CONSTRUCTION

Integral structure manufacturing process

The hull/deck/main bulkhead joints are ensured by carbon fiber structural bonding and filleting. The entire hull/deck unit is a one-piece, non-deformable structure with exceptional stiffness and durability.

Sport structure and finish

- Hulls and deck in PVC/glass and carbon cloth sandwich infused by Vinylester resin with anti-osmotic qualities.
- Coachroof, chainplate reinforcements and omega hull and deck reinforcements in carbon cloth impregnated with Vinylester resin.
- Main structural bulkheads (PVC/carbon cloth sandwich) infused with Vinylester resin with monolithic UD carbon fabric angle.
- Bilges painted in light gray.
- Hull finish in gray gel coat
- Matt finish under nacelle
- Finish under nacelle leading edge and aft beam in gloss.
- White gel coat deck with integrated non-slip
- Composite daggerboards sliding on PTFE bearings without wells
- Hull-deck joint by gluing with lamination at the stress zones (leading edge, chain plates, beam and compression beam cleats)

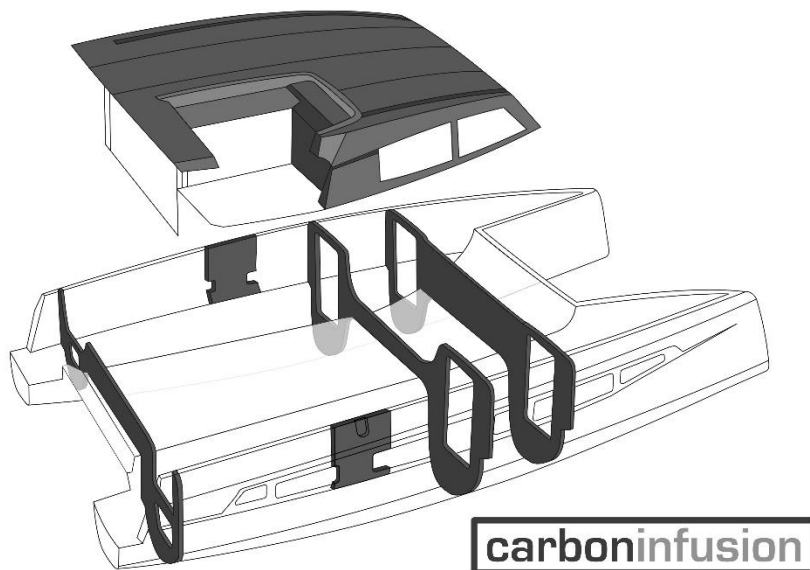

EXTERIORS

Mast / Rigging

- Anodized aluminum mast
- LED masthead anchor light
- Exits for mainsail halyard, solent halyard, Code 0 or Gennaker halyard and topping lift
- Combined LED steaming light/decklight
- Luff track on ball bearing slides
- Padeye for attaching lazyjacks
- Masthead wind instrument
- Anodized aluminum boom with spacers and lazy bag
- Anodised aluminium front beam with LED stern light
- Anodized aluminum compression beam
- Hinged bowsprit with made of dyneema fabric
- Rod rigging stainless steel forestay
- Furler on forestay
- 2 stainless steel 1 x 19 capshrouds
- 2 lower shrouds

Sails

Reinforced sails:

- 90 m² fully battened, triradial cut, square-topped, mainsail in PRORADIAL, with 3 reefs, 6-row stitching
- 50 m² self-tacking solent in PRORADIAL, triradial cut, 6-row stitching, UV strip in same color as the lazybag

Running rigging

- All running rigging returned to the helm station
- Mainsail halyard with Dyneema core
- Double mainsheet
- Solent halyard at the foot of the mast
- Code 0/Gennaker halyard led back to the steering station
- Solent sheet led back to the steering station
- Solent furling line
- 3 Reefing lines (N°1, N°2, N°3)
- 3 Reefing points (N°1, N°2, N°3)
- Boom topping lift
- 2 Flag halyards
- Adjustable foot tension

Deck hardware

Centralized fittings near the helm station

- 1 Electric Winch (Harken - radial) for mainsail halyard + 3 reefing lines + headsail halyards (if optional)
- 1 Manual Winch (Harken radial) 3 Reefing lines + Edge + Boom topping lift + Mainsheet
- 1 Winch (Harken radial): Solent sheet + Spinnaker halyard (if optional)
- 2 Winch cranks + cases

Mainsail:

- Double purchase, 4-line sheeting



- 2 Padeyes for mainsheet

Solent:

- 1 Sheet track forward of the mast
- 1 Track single slider for halyard tensioning
- 1 Furling line led back to the helm station with clutch
- 1 Sheet clutch

Sail maneuvers led back to the helm station:

- 3 Reefing tack clutches
- 3 Reefing line clutches
- 1 Clutch for mainsail foot tension
- 1 Main halyard clutch
- 1 Topping lift clutch
- 1 Solent clutch

Mainsail cover:

- Battened lazy bag in fabric, 4 choice of colors and adjustable Ø 8 mm lazy jacks in Dyneema

Anchoring

- Lofrans 1700W/12V windlass with vertical axis
- Corded remote control connected in the anchor locker
- Windlass handle for manual operation
- Pivoting bow roller in stainless steel for main anchor

Deck equipment

- 2 Smoked plexiglass panels for access to the bow lockers
- 2 Polyester panels for engine hold access with diamond point anti-slip
- 2 Polyester panels for access to leading edge lockers with non-slip diamond edge
- 1 Roof hatch over galley in smoked plexiglass with blind and mosquito net
- Gas struts for all deck hatches
- 2 White lacquered aluminum davits with Spinlock clutches on each davit
- 2 Tender hoisting tackles with stainless steel snap shackles on dedicated winch
- 2 Daggerboards sliding on PTFE bearings and electrically operated from the helm station

Safety:

- Lifeline attachment points around the coachroof
- Handrails on coachroof in solid teak wood
- Handrails on the edge of the rear skirts
- High-comfort trampoline with braided mesh, lashed mesh by mesh.
- 2 Forward pulpits with white Polywood seat
- Aft railing in stainless steel tube
- 8 Stanchions
- Double Dyneema retroreflective guardwires
- 2 Gates for gangway
- 6 Large size aluminum mooring cleats
- 2 Aluminum mooring cleats inboard side of sugarscoops

Coachroof top:

- 3 LED exterior ceiling lights on dimmer
- Sternlight LED

Exterior equipment

- Access to the deck via GRP steps anti-slip diamond type
- 1 Bench seat lounger in the aft beam large storage locker with RTM polyester on gaz struts
- 1 Built-in bathing ladder port transom with handrail on the top of the skirt
- 1 handheld shower (hot/cold water)
- 1 Passerelle socket in starboard sugarscoop
- 1 Emergency tiller access plug on each sugarscoop
- 4 Skirt step lights - courtesy LED
- Name and home port
- Batyline and pvc butt pocket under the winches at the control station

Foredeck (Mast foot area)

- Large anchor locker with access by locker lid on ram
- Space for life raft with automatic "CATANA" release system and swivel hatch under nacelle.

Helm stations / Rudders

- Helm seat with footrest + solid teak duckboard
- Helm console integrated into the roof as a backrest for the maneuvering station
- Magnetic steering compass with protective housing and lighting
- Gray fiberglass steering wheels Ø 1000 mm
- 2 Suspended balanced rudder blades, mounted on JP3 spherical self-aligning bearings
- 1 Emergency tiller
- Mechanical transmission steering system with Dyneema lines and ultra low friction ball bearings
- Manual engine controls at the helm station with engine instruments and alarms
Large space for marine electronics

Sail Locker

- LED lighting
- Removable ladders fixed on the inside of the hulls.

INTERIOR LAYOUTS

General

- Fronts of the furniture : PVC foam sandwich, laminated decor
- Laminated PVC foam sandwich floors in the hulls and PVC cladding on the nacelle
- PVC ceiling and liner linings

Comfortable cockpit completely open to the outside

- Saloon accessible by 4-leaf sliding door sliding to starboard with clear glazing.
- Panoramic view through 3 large forward windows and wide lateral plexiglas windows
- Ventilation through 2 large opening front bay windows and 2 side bay windows for total opening
- L-shaped seat with storage
- Folding saloon table with integrated bar for 8 people
- Dimmable recessed LED spotlights
- Courtesy lighting in the ceiling
- 2 AC outlets (220/50hz or 115/60hz)
- Cockpit upholstery: HR 30 foam + single stitching + spradling fabrics - Marlin: 4 colours to choose from + aeration of the covers by eyelets

Raised saloon for panoramic view

- Deep L-shaped seat that can act as a watchkeeper's berth
- Coffee table
- Under-seat storage & direct access for the electrical systems : Battery converter, switch..
- 1 reading light + dedicated switch
- Saloon upholstery: HR 30 foam + single stitching + spradling fabrics - Marlin: 4 colours to choose from + aeration of the covers by eyelets

Galley:

- Galley with large resin countertop
- 1 stainless steel sink 1½ bowl
- 1 Two-way tap supplying potabilised water by microfiltration (carbon filter) on one side and fresh water from tanks on the other.
- 1 selective waste bin
- Pressurized hot and cold water
- 4 AC outlets (220/50hz or 115/60hz)
- 1 x 4-burner gas hob with pot holder and gas shutoff tap
- 1 stainless steel gas oven with grill and gas shutoff tap
- Combined Fridge 267L (9.4 cu ft) + Freezer 98L (3.5 cu ft)
- Space provided for a 9-cover dishwasher + extra fridge + cellar (options)
- Dimmable LED spotlights

- Plenty of storage space:
 - o Pot and pan drawers under the oven
 - o Sliding grocery cupboard to the right of the oven
 - o 2 high cabinets above the cooker
 - o Large corner storage box with access from the cockpit sofa
 - o Cabinet with door under the sink
 - o Large cupboard with 3 shelves and 2 large drawers for cutlery + cutlery tray

- Large drawer to the left of the fridge/freezer combination

Chart table:

- Large chart table with instrument console
- Console for electrical switch panel
- Chart table seat on swivel
- 1 chart table reading light
- Technical access under chart table
- 1 AC outlet (220/50hz or 115/60hz)
- 1 USB outlet

Owner's hull (Port side)

- Access via wide companionway steps with the same floor covering as the hull.
- Hull closure by lockable sliding door

Aft cabin owner's version:

- Semi-Island bed (1,60m. x 1,90m.) with padded headboard
- One-piece bed base + hydraulic cylinders with direct access to the heater or air-cond (options)
- 1 bedside tables
- 1 Large shelf with storage space on the inboard side
- 1 Drawer and multiple storage under-bunk
- 1 wardrobe + 2 cupboard with shelves
- 1 Large chest of drawers with shelves with dressing table
- 1 storage unit in the wall unit with flap
- Mirror on sliding doors
- Ventilation by hull portholes + 1 porthole in aft bay window, giving onto the deck
- Large fixed window in outboard topsides
- General lighting by LED spotlights in the ceiling with dimmer and 2 bedside reading lights.
- 1 AC outlet (220/50hz or 115/60hz)
- 1 double USB port socket
- dimmable courtesy lighting under the bed

Owner's bathroom (3-cabin version):

- Private access from the cabin
- Built-in resin washbasin
- 1 Vanity unit high with mirror and lighting
- 3 base furniture with door
- 1 drawer under the basin
- Shower :
 - Separate with glass panel and lock
 - Shower column with high head and hand shower
 - Storage for toiletries

- Ventilation window with blackout curtain
- White polywood duckboard and bench
- Bathroom accessories (1 coat hook)
- Lighting by large fixed window
- Ventilation through hull portholes
- LED ceiling spotlight on dimmer switch
- Storage under basin
- Space for optional washing machine
- Large storage unit above the washing machine option
- 1 AC outlet (220/50hz or 115/60hz) under the sink
- Bench seat between the shower and the vanity unit

Separate owner's heads compartment (3-cabin version):

- Fresh-water electric W.C.
- Ceiling LED spotlight
- Porthole with blackout blind
- 1 toilet brush and toilet paper holder

Guest hull (Starboard)

Aft guest cabin:

- Access by door from the passageway
- Semi-Island bed (1,60m. x 1,90m.) with padded headboard
- One-piece bed base + hydraulic cylinders with direct access to the heater or aircond (options)
- 1 Large shelf with storage space on the inboard side
- Storage cupboards and 1 hanging locker
- Ventilation by 2 hull portholes (in plexiglas window) + 1 porthole in fixed aft window giving onto deck
- General lighting by LED spotlights on dimmer and 2 bedside reading lights
- 1 AC outlet (220/50hz or 115/60hz)
- 1 x double USB outlet
- dimmable courtesy lighting under the bed

Heads compartment 1-shower/1-WC version:

- 1 Fresh water electric W.C.
- Toilet accessories (brush and toilet paper holder)
- 1 Large separate shower with satin plexiglas screen and ventilation via 1 hull porthole
- Bathroom accessories (1 coat hook, toiletries storage)
- LED Spotlights
- Unit with built-in basin and storage
- Wall cabinet with mirror and lighting
- 1 AC outlet in wall cabinet

Heads compartment 2-shower/2-WC version:

- 2 Fresh water electric W.C.s

- Toilet accessories (brush and toilet paper holder)
- 2 separate showers with satin plexiglas screens
- Bathroom accessories (1 coat hook)
- LED Spotlights
- Unit with recessed basin and storage, mirror and lighting

Forward guest cabin:

- Access by door from the passageway
- 2 bunk beds (0,80m. x 1,90m.) + (0,75m. x 1,80m.)
 - o Foldable upper bunk
 - o Extendable lower bunk with optional duckboard
- Storage space under the low berth
- Large shelf on inboard topsides
- Storage cupboards and hanging locker
- Big Storage box with upholstery for seats
- Ventilation by hull window (on plexiglass)
- General lighting by LED spotlights on dimmer and 2 bedside reading lights
- 1 AC outlet (220/50hz or 115/60hz)
- 1 x USB outlet
- Low-level courtesy lighting



TECHNICAL EQUIPMENTS

Engine compartments

- 2 x 45 hp YANMAR diesel engines, soundproofed and totally separated from the interior.
- Engine panels and controls via mechanical cables at the helm station
- 2 saildrive transmission systems
- 2 fixed three-blade propellers
- 1 Diesel filter / water separator per engine
- Location for Watermaker
- Engine compartment illuminated by two LED striplights
- Gray gelcoat finish below waterline areas

Plumbing

- 2 independent 400L (113 US gal) diesel tanks with filler necks and overfill protection system (CE)
- Electric fuel gauges on screen at the chart table
- Diesel shut-off valves
- 2 Freshwater tanks of 400 L (105 US gal) each
- Electric water gauges on screen at chart table
- 2 Water pumps with pressure tank and safety interconnection system
- 2 electric water heaters (60 L)
- 2 electric bilge pumps interior passageways
- Automatic activation of the 4 bilge pumps with visual alarm at the chart table
- 4 external manual bilge pumps
- Shower drains by automatic shower sump pumps
- Fully automatic black and gray water treatment plant
- Independent faucet at the galley sink providing microfiltered drinking water

Electricity

- 1 x 12V engine starter battery per engine
- 2 engine alternators, 12V 125A
- 1 x 12V service battery bank, 400AH Lithium (LiFePo4)
- 1 charger, 12V/30A
- Control of functions at the chart table via color touch screen
- Monitoring: tanks, batteries, alarm management
- 1 shore power connection 220V (115V in option) with 15 m power lead

COMMISSIONING

Rigging :

- Assembly and installation of the standing and running rigging
- Optimal tensioning and adjustment of the mast
- Fitting of the boom
- Installation of the lazy bag and lazy jack

Launching of the ship :

- Watertightness tests
- Engine and propeller tests

Moorings Pack & Fender Fendertex® type :

- 8 black fenders



- 8 black fenders with red CATANA marking
- 1 transport bag
- 8 fenders with splices
- 1 inflation nozzle.
- 5 mooring lines

Sails & Fittings :

- Installation of the mainsail : fixing the cars, installation of the reefs and sheets.
- Installation of the genoa and code 0: fitting on the forestay, preparation of the sheets and adjustment of the furler

